

United States of America
Department of Transportation -- Federal Aviation Administration
Supplemental Type Certificate

Number SA1072GL

This certificate issued to Aero Cables Corp.
11953 S. Spaulding School Road
Unit 2
Plainfield, IL 60544

certifies that the change in the type design for the following product with the limitations and conditions therefor as specified hereon meets the airworthiness requirements of Part 3 of the Civil Air Regulations.
(See Type Certificate Data Sheet 2A13 for complete certification basis.)

Original Product - Type Certificate Number : 2A13

Make : The New Piper Aircraft, Inc.

Model : PA-28-140, -150, -151, -160, -161, -180, -181, -235, -236, -201T;
PA-28S-160, -180; PA-28R-180, -200, -201, -201T;
PA-28RT-201, 201T

Description of Type Design Change:

Installation of a Cooling Shroud on engine driven dry air pumps in accordance with S & M Products Report No. 8, revision 00 dated July 21, 1986, or other FAA approved revision.

Limitations and Conditions :

- 1) Compatibility of this design change with previously approved modifications must be determined by the installer.
- 2) If the holder agrees to permit another person to use this certificate to alter the product, the holder shall give the other person written evidence of that permission.

This certificate and the supporting data which is the basis for approval shall remain in effect until surrendered, suspended, revoked or a termination date is otherwise established by the Administrator of the Federal Aviation Administration.

Date of application : July 21, 1986

Date reissued : March 19, 2004; June 15, 2004

Date of issuance : October 9, 1986

Date amended : October 28, 1986



By direction of the Administrator

Ray E. Boffone
(Signature)

for Charles L. Smalley
Manager, Systems and Flight Test Branch
Chicago Aircraft Certification Office

(Title)

S&M Report No. 8
Revision 00
July 21, 1986

KIT NO. 10 - Vacuum Pump Cooling Kit for Airborne Model 200 thru 212CW and CC Dry Air Pumps

KIT NO. 11 - Vacuum Pump Cooling Kit for EDO-AIRE Model 1U128, 1U128A and 1U128B; and SIGMA TEK Model 1U128B Dry Air Pumps

PIPER PA-28-140, PA-28-150, PA-28-160, PA-28-180, PA-28-235, PA-28S-235, PA-28S-160, PA-28S-180, PA-28R-180, PA-28R-200, PA-28-151, PA-28-181, PA-28-161, PA-28R-201, PA-28R-201T, PA-28-236, PA-28RT-201, PA-28RT-201T, PA-28-201T TC 2A13

REVISION PAGE

<u>Table of Contents</u>	<u>Page No.</u>	<u>Revision/Page</u>
Revision Page	1	00, 07-21-86
Parts List for Kits No. 10 and 11	2	00, 07-21-86
Drawing List for Kits No. 10 and 11	3	00, 07-21-86
Installation Instructions	4 & 5	00, 07-21-86
Flange Installation Drawings:	6	00, 07-21-86
Drawing M (Piper PA-28-151, PA-28-161)		
Drawing N-1 (Piper PA-28-235, PA-28S-235)		
Drawing N-2 (Piper PA-28-236)		
Drawing P (Piper PA-28-201T, PA-28R-201T, PA-28RT-201T)		
Flange Installation Drawings:	7	00, 07-21-86
Drawing Q (Piper PA-28-140, PA-28-150, PA-28-160, PA-28S-160)		
Drawing R (Piper PA-28-180, PA-28S-180, PA-28R-180, PA-28R-200, PA-28-181, PA-28R-201, PA-28RT-201)		
STC and Eligibility Listing	8	00, 07-21-86
Drawing 1 (View of Cooling Kit No. 10)	9	00, 07-21-86
Drawing 2 (View of Cooling Kit No. 11)	10	00, 07-21-86
Material Specifications	11 & 11a	00, 07-21-86
Drawing of Cooling Shroud Model 2CDH	12	00, 07-21-86
Drawing of Cooling Shroud Model 4ADH	13	00, 07-21-86

F A A
A P P R O V E D

OCT 09 1986

CHICAGO AIRCRAFT
CERTIFICATION OFFICE
CENTRAL REGION

ACE/BOC
WWD

S&M Report No. 8
 Revision 00
 July 21, 1986

KIT NO. 10 - Vacuum Pump Cooling Kit for Airborne Model 200 thru 212CW and CC Dry Air Pumps

KIT NO. 11 - Vacuum Pump Cooling Kit for EDO-AIRE Model 1U128, 1U128A and 1U128B; and SIGMA TEK Model 1U128B Dry Air Pumps

PIPER PA-28-140, PA-28-150, PA-28-160, PA-28-180, PA-28-235, PA-28S-235, PA-28S-160, PA-28S-180, PA-28R-180, PA-28R-200, PA-28-151, PA-28-181, PA-28-161, PA-28R-201, PA-28R-201T, PA-28-236, PA-28RT-201, PA-28RT-201T, PA-28-201T TC 2A13

KIT NO. 10 PARTS LIST - AIRBORNE INSTALLATION

<u>Quantity</u>	<u>Part No.</u>	<u>Description</u>
1	2CDH	Cooling Shroud
1	2CDH-1	Flange
1	2CDH-2	Approx. 13.3" C.A.T. Aeroduct Tubing
2	2CDH-3	Cable Ties
1	Rev. 00, 07-21-86	Installation Instructions
1	Rev. 00, 07-21-86	Flange Installation Drawings
1	Rev. 00, 07-21-86	Kit Installation Drawing (View of Cooling Kit on Pump)
1	Rev. 00, 07-21-86	STC and Eligibility Listing

KIT NO. 11 PARTS LIST - EDO-AIRE & SIGMA TEK INSTALLATION

<u>Quantity</u>	<u>Part No.</u>	<u>Description</u>
1	4ADH	Cooling Shroud
1	2CDH-1	Flange
1	2CDH-2	Approx. 17" C.A.T. Aeroduct Tubing
2	2CDH-3	Cable Ties
1	Rev. 00, 07-21-86	Installation Instructions
1	Rev. 00, 07-21-86	Flange Installation Drawings
1	Rev. 00, 07-21-86	Kit Installation Drawing (View of Cooling Kit on Pump)
1	Rev. 00, 07-21-86	STC and Eligibility Listing

FAA
 APPROVED

OCT 09 1986

CHICAGO AIRCRAFT
 CERTIFICATION OFFICE
 CENTRAL REGION
 ACE/30C
 WUCD

S&M Report No. 8
Revision 00
July 21, 1986

KIT NO. 10 - Vacuum Pump Cooling Kit for Airborne Model 200 thru 212CW and CC Dry Air Pumps

KIT NO. 11 - Vacuum Pump Cooling Kit for EDO-AIRE Model 1U128, 1U128A and 1U128B; and SIGMA TEK Model 1U128B Dry Air Pumps

PIPER PA-28-140, PA-28-150, PA-28-160, PA-28-180, PA-28-235, PA-28S-235, PA-28S-160, PA-28S-180, PA-28R-180, PA-28R-200, PA-28-151, PA-28-181, PA-28-161, PA-28R-201, PA-28R-201T, PA-28-236, PA-28RT-201, PA-28RT-201T, PA-28-201T TC 2A13

DRAWING LIST FOR KIT NO. 10 & KIT NO. 11

<u>Drawing</u>	<u>Kit No.</u>	<u>Description</u>	<u>Page No.</u>
M	10 & 11	PIPER PA-28-151, PA-28-161 - Flange installation location and measurements.	6
N-1	10 & 11	PIPER PA-28-235, PA-28S-235 - Flange installation location and measurements.	6
N-2	10 & 11	PIPER PA-28-236 - Flange installation location and measurements.	6
P	10 & 11	PIPER PA-28-201T, PA-28R-201T, PA-28RT-201T - Flange installation location and measurements.	6
Q	10 & 11	PIPER PA-28-140, PA-28-150, PA-28-160, PA-28S-160 - Flange installation location and measurements.	7
R	10 & 11	PIPER PA-28-180, PA-28S-180, PA-28R-180, PA-28R-200, PA-28-181, PA-28R-201, PA-28RT-201 - Flange installation location and measurements.	7
1	10	View of Cooling Shroud on AIRBORNE Pump, Ducting and Flange	9
2	11	View of Cooling Shroud on EDO-AIRE and SIGMA TEK Pumps, Ducting and Flange	10

KIT NO. 10 - Vacuum Pump Cooling Kit for Airborne Model 200 thru 212CW and CC Dry Air Pumps

KIT NO. 11 - Vacuum Pump Cooling Kit for EDO-AIRE Model 1U128, 1U128A and 1U128B; and SIGMA TEK Model 1U128B Dry Air Pumps

PIPER PA-28-140, PA-28-150, PA-28-160, PA-28-180, PA-28-235, PA-28S-235, PA-28S-160, PA-28S-180, PA-28R-180, PA-28R-200, PA-28-151, PA-28-181, PA-28-161, PA-28R-201, PA-28R-201T, PA-28-236, PA-28RT-201, PA-28RT-201T, PA-28-201T TC 2A13

INSTALLATION INSTRUCTIONS

1. To install Vacuum Pump Cooling Kit No. 10 on Airborne Model 200 thru 212CW and CC Dry Air Pumps, or Vacuum Pump Cooling Kit No. 11 on EDO-AIRE Model 1U128, 1U128A, 1U128B, and SIGMA TEK Model 1U128B Dry Air Pumps installed on the aircraft shown above, proceed according to the following instructions and refer to Flange Installation Drawings M, N, P, Q, & R. For a view of the cooling shroud, ducting and flange, refer to Drawing 1 for Kit No. 10 and Drawing 2 for Kit No. 11.

2. COOLING SHROUD INSTALLATION.

a. To mount the cooling shroud on the vacuum pump, the shroud must be held open slightly while installing. The shroud is made so the cooling exit is not centered with the cooling inlet. Turn over and/or rotate the shroud on the vacuum pump to best compromise the cooling inlet and outlet with other objects that may interfere with them near and around the vacuum pump.

b. On the Airborne installation (Kit No. 10), the shroud may not be able to be slipped on the pump and rotated to the desired position because of interference with other parts. In this case, remove the rear fitting on the pump, slip the shroud on and rotate it, then reinstall the rear fitting. If lubrication of the fitting is needed, use only a spray silicone on the threads, shake off the excess and let it dry before installing the fitting. **DO NOT** use oil, grease or tape on the threads.

c. Optional Shroud Position on Lycoming Engines. Due to tachometer drive interference on some Lycoming engines, an optional position on the shroud may be 1/8" toward the undriven end of the pump, or the shroud can be filed to allow the shroud to center on the pump. **DO NOT** file through the shroud.

3. COOLING DUCT INSTALLATION. Install the cooling duct on the shroud inlet using sealant and a nylon cable tie, as per instructions on Drawing 1 or 2, as applicable. Route the cooling duct to the aft side of the rear engine baffle, avoiding sharp bends, sharp objects and moving parts. Do not cut off excess duct at this time.

4. INSTALLATION OF FLANGE FITTING. (Refer to Drawings M, N, P, Q, R)

a. Make a 1 1/8" hole in the baffle, maintaining a 1" edge distance minimum, or as per drawing.

b. Drill four (4) #40 holes and use washers under rivets on flange side. Install the flange through the baffle from the front. Use sealant between flange and baffle. Install the flanged fitting using four (4) AN470AD-3 rivets or drill four (4) #28 holes and use four (4) AN526-632 screws and AN365-632 nuts and AN960-6 washers.

Installation Instructions (Continued):

c. Cut the cooling duct to length--avoid making it too long or too short for best routing. Try to avoid making over 90 degree bends and sharp bends.

d. Install the cooling duct on the flanged fitting using sealant and a nylon cable tie (see Drawing 1 or 2). Support or tie the cooling duct every 12 inches.

5. SEALING REQUIREMENTS.

a. To compensate for the 7/8" hole in the rear engine baffle, seal holes in the engine baffling at forward and rear corners, the space between the rear baffle and the engine crankcase, where sheet metal corners have holes in them, and where hoses and wires pass through the baffling. Seal enough holes and gaps to exceed .601 square inch, or 1/8" x 5", or 1/4" x 2.5".

b. Use 890 or RTV 106 red high temperature sealants per manufacturers' instructions. Alternate sealants are GE RTV 102, 103, 108, 158; Dow Corning 732 RTV sealants; or equivalents.

6. PAPERWORK.

a. Add the appropriate cooling kit number to the aircraft equipment list.

b. Weight of this kit is .24 lbs.

c. Complete FAA Form 337 and make proper logbook entry of kit installation.

d. These installation instructions will become part of the permanent aircraft records.

S&M Report No. 8
 Revision 00
 July 21, 1986

PIPER PA-28-151, PA-28-161 TC 2A13

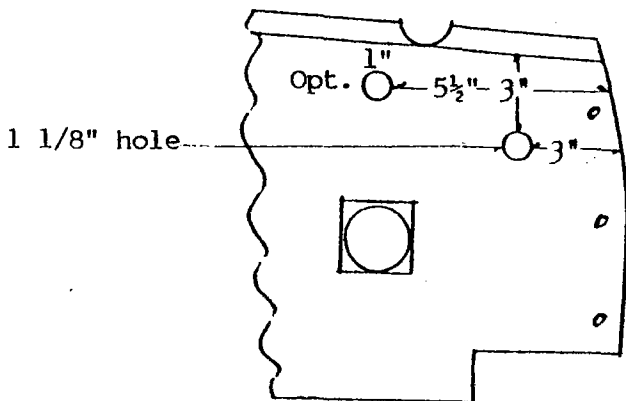

View: R H rear engine baffle, looking forward.

DRAWING M

PIPER PA-28-235, PA-28S-235 TC 2A13

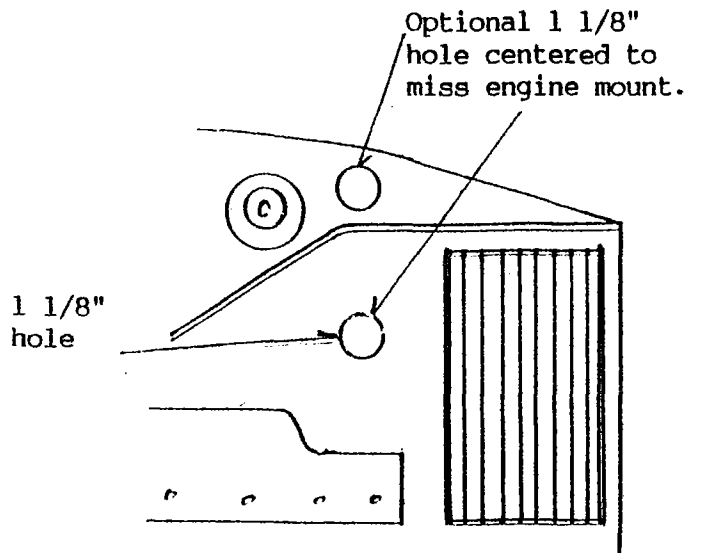

View: R H rear engine baffle, looking forward.

DRAWING N-1

PIPER PA-28-236 TC 2A13

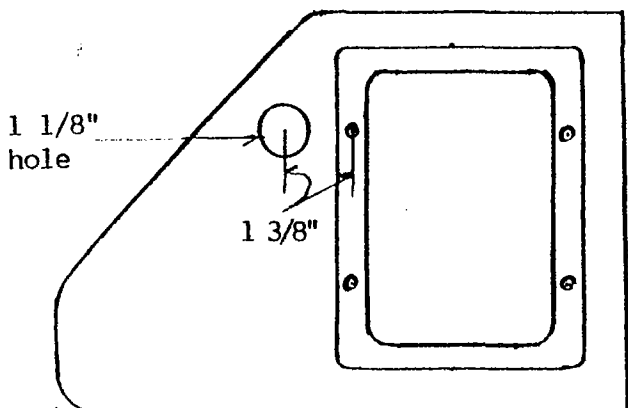

View: R H rear engine baffle, looking forward.

DRAWING N-2

PIPER PA-28-201T, PA-28R-201T,
 PA-28RT-201T TC 2A13

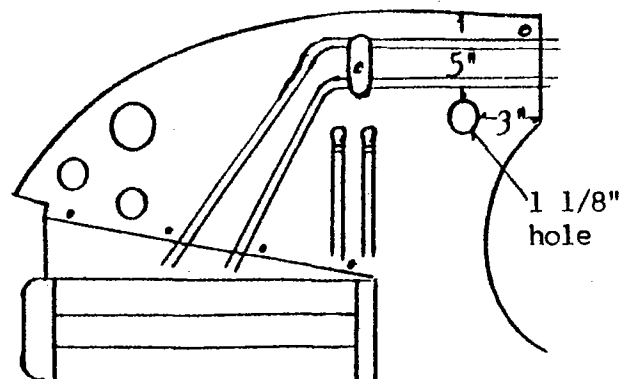

View: L H rear engine baffle, looking forward.

DRAWING P

S&M Report No. 8
Revision 00
July 21, 1986

PIPER PA-28-140, PA-28-150, PA-28-160,
PA-28S-160 TC 2A13

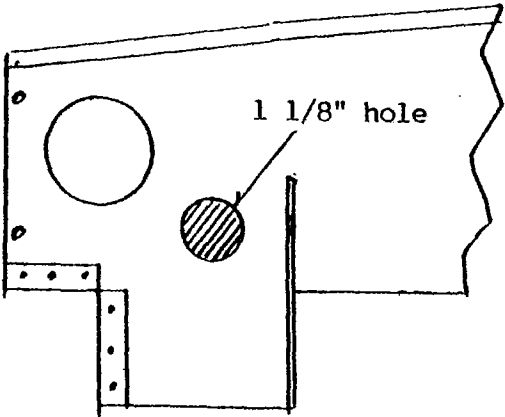

View: R H rear engine baffle,
looking aft.

DRAWING Q

PIPER PA-28-180, PA-28S-180, PA-28R-180,
PA-28R-200, PA-28-181, PA-28R-201,
PA-28RT-201 TC 2A13

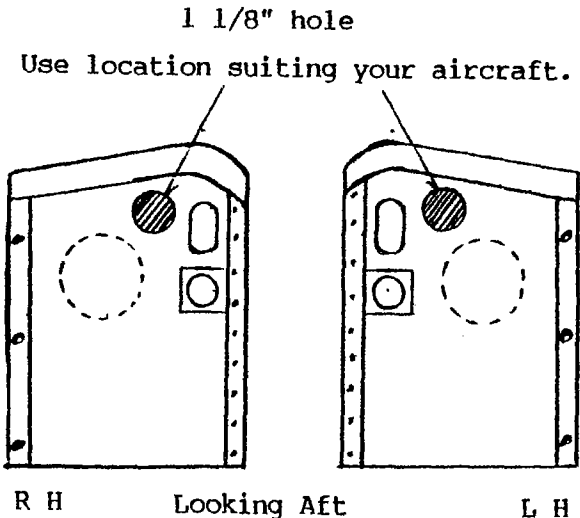

DRAWING R

S&M Report No. 8
Revision 00
July 21, 1986

KIT NO. 10 - Vacuum Pump Cooling Kit for Airborne Model 200 thru 212CW and CC Dry Air Pumps

KIT NO. 11 - Vacuum Pump Cooling Kit for EDO-AIRE Model 1U128, 1U128A and 1U128B; and SIGMA TEK Model 1U128B Dry Air Pumps

PIPER PA-28-140, PA-28-150, PA-28-160, PA-28-180, PA-28-235, PA-28S-235, PA-28S-160, PA-28S-180, PA-28R-180, PA-28R-200, PA-28-151, PA-28-181, PA-28-161, PA-28R-201, PA-28R-201T, PA-28-236, PA-28RT-201, PA-28RT-201T, PA-28-201T TC 2A13

STC AND ELIGIBILITY LISTING

<u>TC Number</u>	<u>STC Number</u>	<u>Eligibility</u>
3A12	SA702GL	CESSNA 172K, 172L, 172M, 172N, 172P, 172Q
3A13	SA777GL	CESSNA 182G, 182H, 182J, 182K, 182L, 182M, 182N, 182P, 182Q, R182, TR182, T182
3A15	SA1034GL	BEECH F33A, S35, V35, V35A, V35B, 36, A36, A36TC, B36TC
3A19	SA1003GL	CESSNA 152, A152
3A21	SA785GL	CESSNA 210L, 210M, 210N, T210L, T210M, T210N, 210R, T210R, P210N, P210R
A4CE	SA791GL	CESSNA 206, P206, P206A, P206B, P206C, P206D, P206E, U206, U206A, U206B, U206C, U206D, U206E, U206F, U206G, TP206A, TP206B, TP206C, TP206D, TP206E, TU206A, TU206B, TU206C, TU206D, TU206E, TU206F, TU206G
A7SO	SA1015GL	PIPER PA-34-200T, PA-34-220T
2A13	Pending	PIPER PA-28-140, PA-28-150, PA-28-160, PA-28-180, PA-28-235, PA-28S-235, PA-28S-160, PA-28S-180, PA-28R-180, PA-28R-200, PA-28-151, PA-28-181, PA-28-161, PA-28R-201, PA-28R-201T, PA-28-236, PA-28RT-201, PA-28RT-201T, PA-28-201T

KIT NO. 10

VIEW OF COOLING SHROUD ON AIRBORNE 200-212CW & CC PUMPS, DUCTING & FLANGE

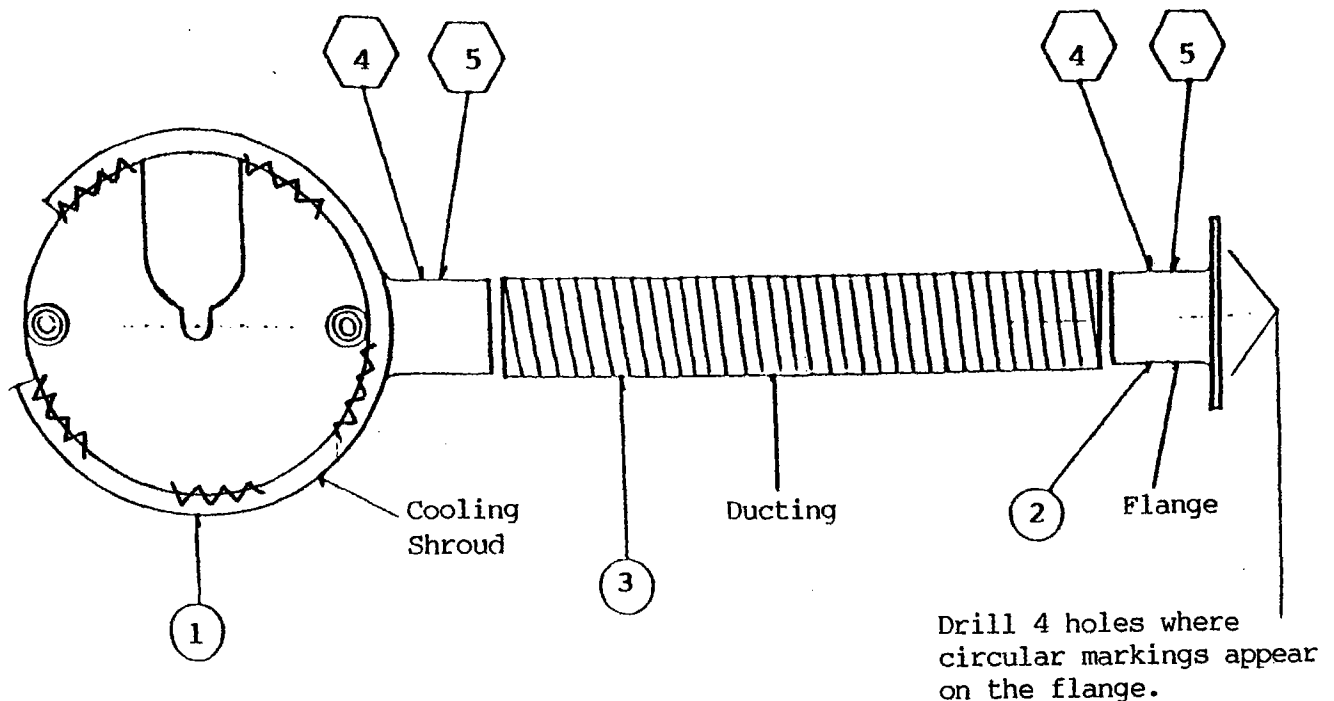

Note: Shroud must be centered on the pump.

4 Cable Ties - Attach these around ducting at inlet of shroud and outlet of flange after ducting has been sealed into place on the inlet and outlet.

5 Sealant - Place sealant on outside of shroud inlet and flange outlet, then push ducting into place. For type of sealant to be used, refer to paragraph 5b of Installation Instructions. Note: If cooling shroud appears to rotate easily after installation, it may be advisable to place a sealant fillet between shroud and pump as shown.

DRAWING 1

Item	Qty	Nomenclature	Part No.
5	A/R	Sealant	
4	2	Cable Ties	2CDH-3
3	A/R	Ducting	2CDH-2
2	1	Flange	2CDH-1
1	1	Shroud	2CDH

S&M PRODUCTS
 2515 E. Bonnie Brook Lane
 Waukegan, IL 60087

Rev. 00 Date: 07-21-86

KIT NO. 11

View of Cooling Shroud on EDO-AIRE & SIGMA TEK Pumps, Ducting & Flange

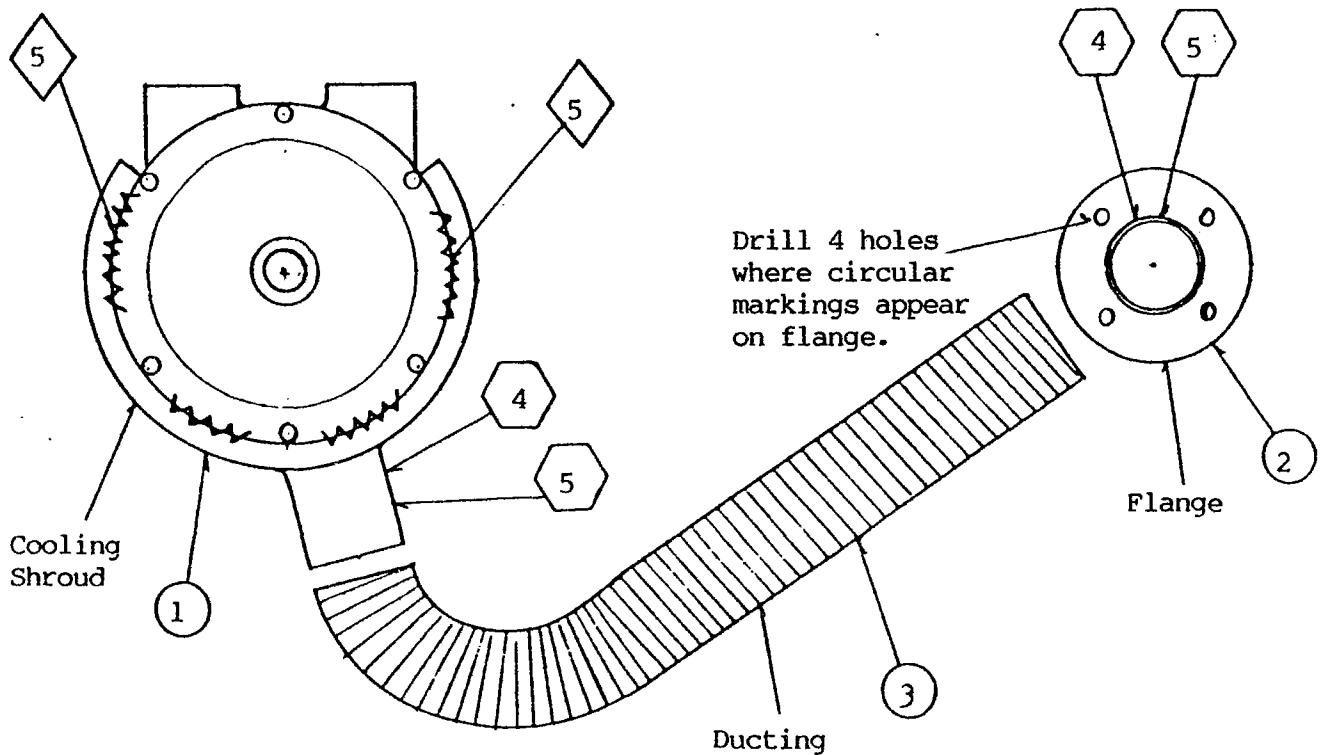

Note: Shroud must be centered on the pump. On some installations the pump may have to be rotated on the mounting pad because of interference with other objects.

- 4 Cable Ties - Attach these around ducting at inlet of shroud and outlet of flange after ducting has been sealed into place on the inlet and outlet.
- 5 Sealant - Place sealant on outside of shroud inlet and flange outlet, then push ducting into place. For type of sealant to be used, refer to paragraph 5b of Installation Instructions.
- 5 Apply sealant fillet between shroud and pump, at the rear of the pump, as shown, to prevent shifting of shroud on pump.

DRAWING 2

Item	Qty	Nomenclature	Part No.
5	A/R	Sealant	
4	2	Cable Ties	2CDH-3
3	A/R	Ducting	2CDH-2
2	1	Flange	2CDH-1
1	1	Shroud	4ADH

S&M PRODUCTS
 2515 E. Bonnie Brook Lane
 Waukegan, IL 60087

Rev. 00, 7-21-86